

Assembly Instructions

The package contains 3 sheets, two identical and one different sheet.

After assembly the trays are put in two layers in the original game box.

Ordinary PVA glue is required when assembling each tray.

Please make sure you dry-assemble each tray correctly before gluing it together.

Please check www.foldedspace.net for general assembly tips.

FS-PRAG

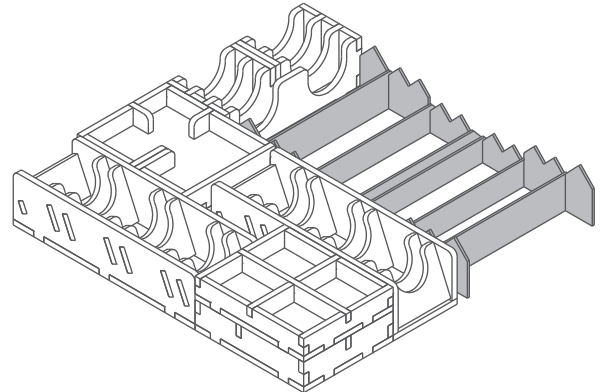

Sheet A1

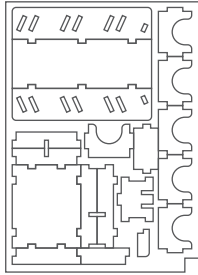

Sheet A2

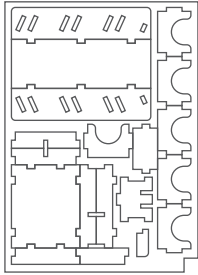

Sheet B1

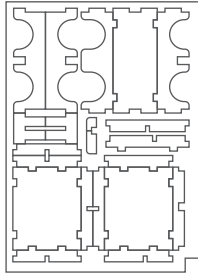

Tray 1a & 1b (the trays are identical)

Sheet A1

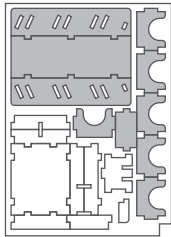

Sheet A2

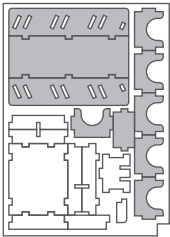

Step 1

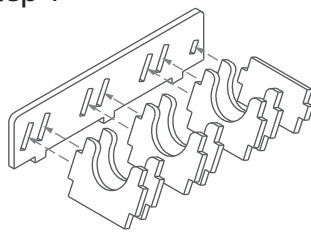

Step 2

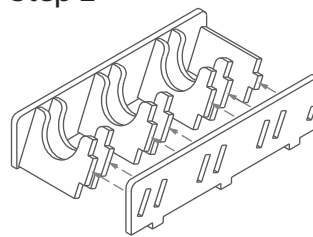

Step 3

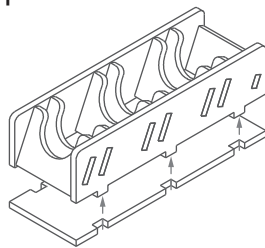

Finished tray

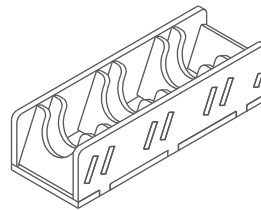

Tray 2

Sheet A1, A2

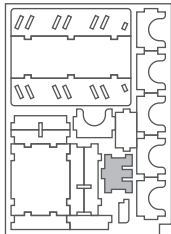

Sheet B1

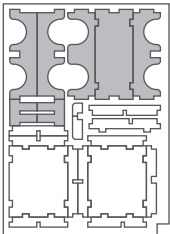

Step 1

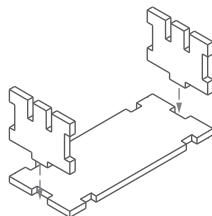

Step 2

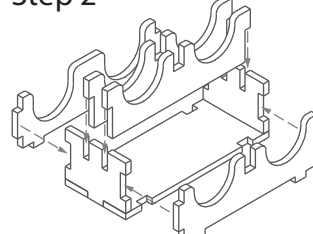

Step 3

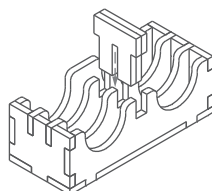

Finished tray

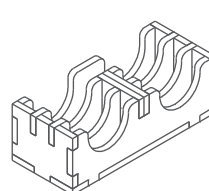

Tray 3a & 3b

(the trays are identical)

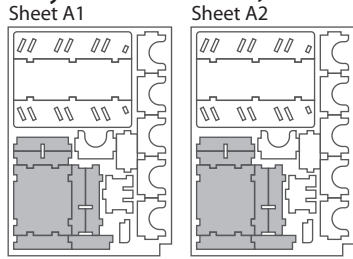

Step 1

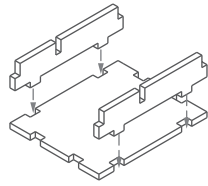

Step 2

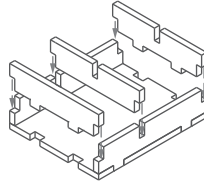

Step 3

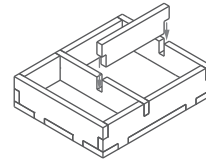

Finished tray

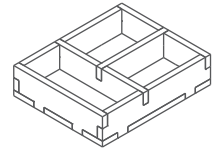

Tray 4

Sheet A1, A2

Sheet B1

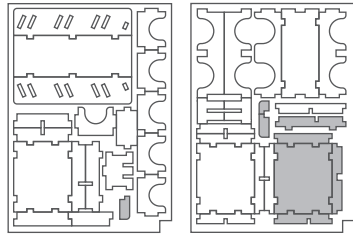

Step 1

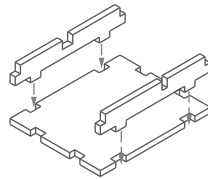

Step 2

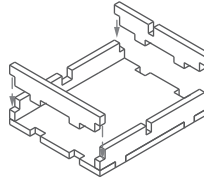

Step 3

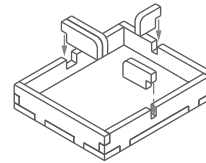

Finished tray

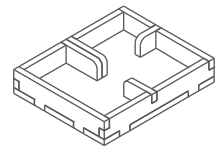

Tray 5

Sheet B1

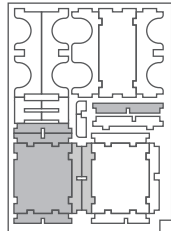

Step 1

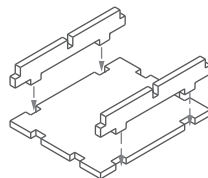

Step 2

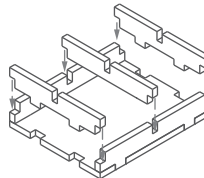

Step 3

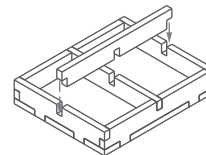

Finished tray

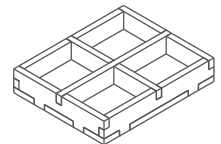

FS-PRAG

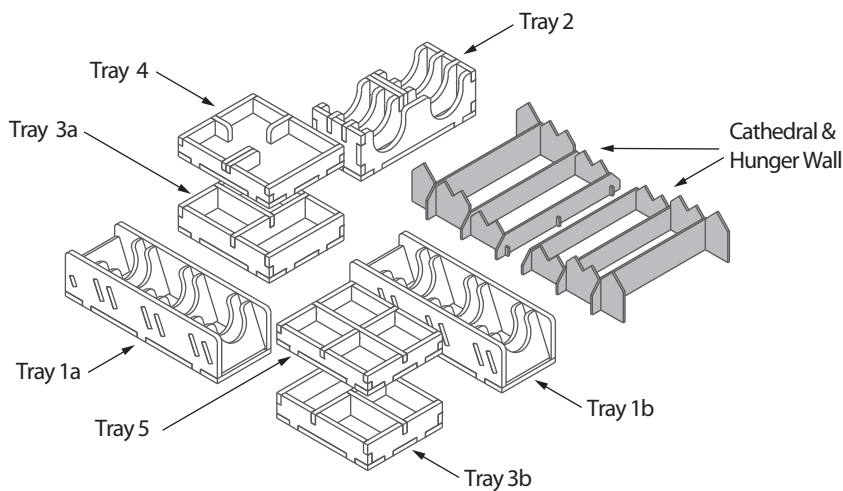

Please check www.foldedspace.net for photos of this insert in use.

Tray legend:

- Tray 1a - era I upgrade, building and wall tiles
- Tray 1b - era II upgrade, building and wall tiles
- Tray 2 - technology and alternate cathedral/hunger wall tiles
- Tray 3a - king's road tiles, egg tokens, and production tiles with 5 point token & brown cubes
- Tray 3b - bonus and windows tokens
- Tray 4 - plaza, action & bridge tiles
- Tray 5 - player pieces

Note: the bridge is placed on top of the cathedral and hunger wall stands. The boards and player boards in this game are complex, so please check our site product page to see how they fit together in the box.